

# Testing airborne radios to the limits

## Application

Replace extensive field tests on fast hopping radios by simulating real-world radio link conditions in the lab

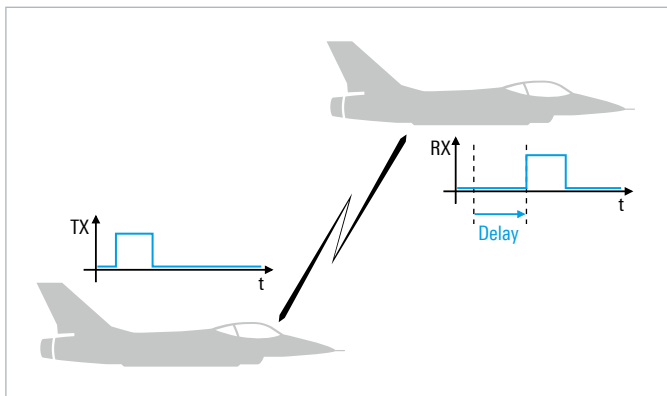

Communications links over long distances cause signal delays that challenge military waveform and radio designs.

### Your task

Modern military communications systems based on software defined radios (SDR) utilize time-critical complex waveforms that can have extremely short synchronization sequences like those in the hopping waveforms of SATURN or R&S®SECOS. In addition, wideband frequency hopping schemes are employed as electronic protective measures (EPM) to avoid jamming. Such hopping sequences cover frequency bandwidths far beyond 100 MHz with hopping rates of hundreds or even thousands of hops per second.

Before secure communications take place, all radio systems involved are synchronized to a master clock. Subsequently, each radio follows the same master-defined hopping scheme independently, relying solely on its internal system clock.

The synchronization window for establishing a connection between two radios is very short. Time delays and differences in the time-keeping accuracy of the individual system clocks can become very critical. System clocks are frequently resynchronized through the master, which reduces the influence of the clock differences. But the radios must always be able to cope with the time delays, as well as with the signal characteristics resulting from the arbitrary hopping schemes.

Especially airborne radios are subject to extreme conditions. Long distances cause considerable time delays to the transmitted signals. Radio waves propagate with the speed of light, leading to time delays of about 1 ms per 300 km distance between communicating radios. In airborne line of sight (LOS) communications, distances of a few 100 km are typical. In the worst case, a communications link cannot be established.

The performance of hopping radio systems under such worst case conditions needs to be verified by radio manufacturers to optimize their designs and by test houses to verify the compliance of a radio with the specification. Usually, test houses rent helicopters, an airfield, antennas and personnel to carry out "real-world" tests, which are very costly and time-consuming. The test results of this conventional approach are influenced and falsified by many known and unknown sources of errors, such as antenna placement and other parameters.

### T&M solution

The Rohde & Schwarz test solution for fast hopping radio systems combines versatility and ease of use with time-saving and cost-efficiency. The combination of the R&S®SMU200A vector signal generator with the R&S®FSG or R&S®FSQ signal analyzer accomplishes real-world test scenarios. The fading option of the R&S®SMU200A supports various fading scenarios. This includes static delay time and velocity simulation up to hypersonic speed to simulate a real-world environment in the laboratory.

75 Years of Driving Innovation



ROHDE & SCHWARZ

Aerospace & Defense  
Test & Measurement

Application Card | 01.00  
Testing airborne radios to the limits

A typical setup for testing the compliance with the equipment specifications of a transceiver is illustrated below. Initially, the transceiver under test (RX) and a reference transceiver (TX) are synchronized, for example by a control software tool which is connected via MIL-STD-1553B data bus. For the test, the reference transceiver (TX) sends an RF signal to the R&S®FSG/R&S®FSQ signal analyzer, where it is down-converted to the baseband. The resulting digital I/Q stream is forwarded in realtime to the R&S®SMU200A vector signal generator. Its internal fading option applies the intended delay, fading and Doppler speed scenario to the signal to simulate a real-world environment. The test signal gets up-converted to the RF before being passed on to the transceiver under test (RX) for demodulating the signal content. Both the reference signal and the demodulated signal are fed into an oscilloscope, such as the HAMEG®HMO3524, for comparison.

By applying various “environmental” scenarios through the fading option of the R&S®SMU200A, the performance limits of the transceiver under test (RX) are quickly detected. The R&S®FSG and R&S®FSQ support realtime streaming up to a signal analysis bandwidth of 28 MHz. Hopping waveforms exceeding this bandwidth are typically tested by utilizing reduced bandwidth hopping schemes provided by the radio manufacturer.

Such a test setup, consisting of the R&S®FSG/R&S®FSQ and the R&S®SMU200A, eliminates unknown sources of errors. It enables manufacturers to optimize their radio designs and allows test houses, military radio users or system integrators to verify compliance with international standards and the supplier radio specifications based on realistic environmental conditions. Preparing hopping radios in the lab for versatile tasks in real-world missions has never been so easy.

### Typical setup for testing an airborne transceiver such as the R&S®M3AR

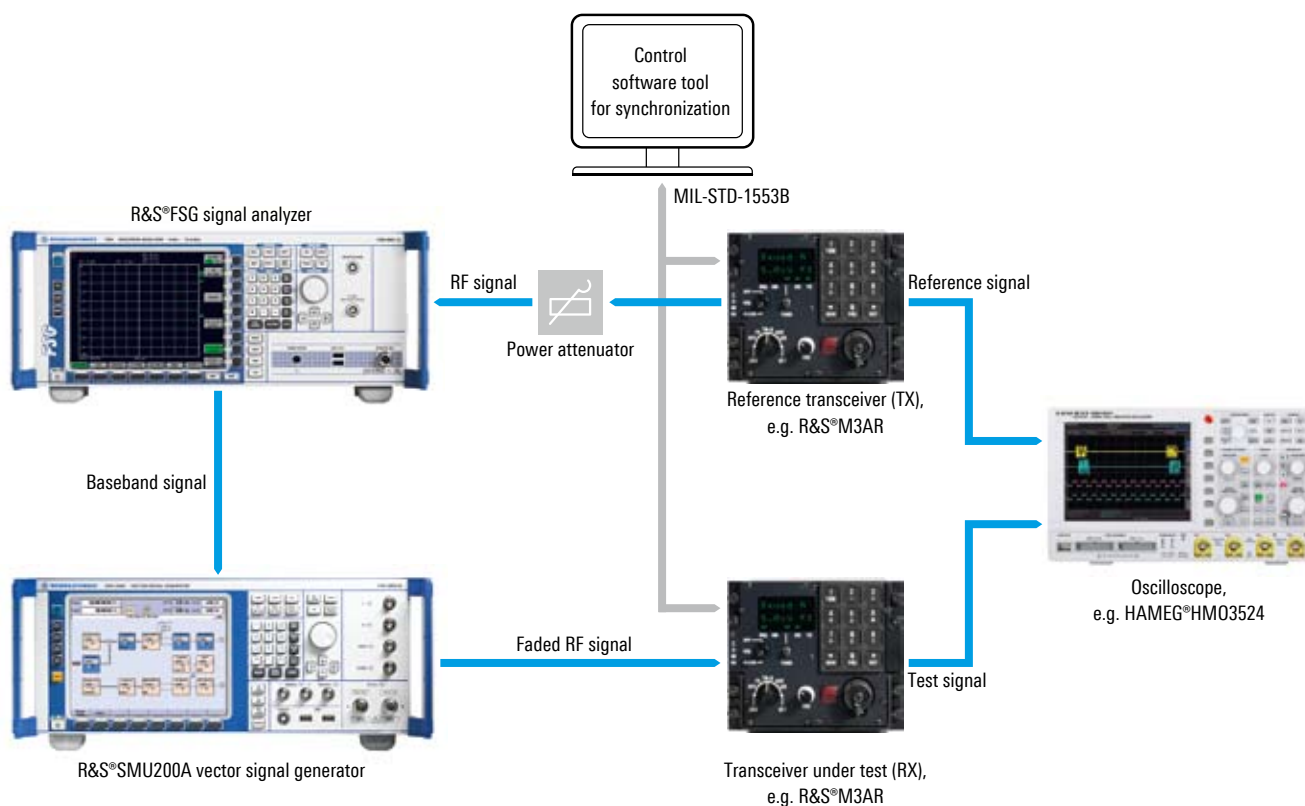

Various signal delays are simulated using the R&S®FSG or R&S®FSQ signal analyzer and the R&S®SMU200A vector signal generator to verify the performance limit of the communications link between the reference transceiver (TX) and the transceiver under test (RX). Timings and demodulated signal contents are verified with a low bandwidth oscilloscope such as the HAMEG®HMO3524.

#### Rohde & Schwarz GmbH & Co. KG

Europe, Africa, Middle East +49 1805 12 42 42\* or +49 89 4129 137 74  
 customersupport@rohde-schwarz.com  
 North America 1 888 TEST RSA (1 888 837 8772)  
 customer.support@rsa.rohde-schwarz.com  
 Latin America +1 410 910 7988  
 customersupport.la@rohde-schwarz.com  
 Asia/Pacific +65 65 13 04 88  
 customersupport.asia@rohde-schwarz.com  
 www.rohde-schwarz.com

R&S® is a registered trademark of Rohde & Schwarz GmbH & Co. KG  
 Trade names are trademarks of the owners  
 Testing airborne radios to the limits | PD 5214.2891.92 | Version 01.00  
 July 2009 | Data without tolerance limits is not binding  
 Subject to change | Printed in Germany (sv)

\*0.14 €/min within German wireline network; rates may vary in other networks (wireline and mobile) and countries.