

Test your multichannel FM car radios

Combining the new R&S®UPP audio analyzers with the R&S®SMB100A signal generators provides the most compact and fastest test solution for modern FM car radios



The new R&S®UPP200/400/800 audio analyzer family.

Your task

FM stereo receivers still represent the majority of audio broadcasting media – especially in the automotive sector, where millions of car radios are manufactured every year. For testing FM stereo receivers, audio test signals must be modulated onto an RF carrier and analyzed after being demodulated by the device under test (DUT).

Special services such as the radio data system (RDS) – which have long been established in many countries – must also be supported by the test system.

The difficult acoustic conditions in a vehicle and the tight space conditions for accommodating the sound transducers prompted manufacturers of modern car hi-fi systems not only to split up the audio frequency range among several loudspeakers, but also to control the speakers via separate amplifier channels. The use of DSP-controlled sound-optimization circuits further perfected this technology, so that usually four to eight amplifier channels are installed. Switching to surround-sound technology in vehicles can result in as many as 16 loudspeakers and amplifier channels, which are implemented in modern car sound systems.

Particularly during the production of modern car radios, signal generators are needed for providing the required RF test signals. Also necessary are powerful audio analyzers which are capable to measure the different audio channels in parallel to reduce test time.

T & M solution

Rohde & Schwarz offers the most compact and fastest test solution for modern FM receivers, featuring signal generation and accurate multichannel audio measurements.

Equipped with the optional stereo/RDS coder (R&S®SMB-B5 option), the R&S®SMB100A signal generator meets all requirements for measuring FM tuners over the full frequency range. The R&S®SMB100A offers an internal LF generator, but the stereo/RDS coder also works with external signals applied to its analog or digital modulation inputs. This solution also generates stereo multiplex signals, including all modes of ARI and RDS information.

Combining the R&S®SMB100A signal generator with the new R&S®UPP200/400/800 audio analyzers creates a general-purpose test system for FM receivers. The great advantage is the automatic synchronization of measurement results. Similarly to other audio applications, the required test signals are generated in the generator section of the audio analyzer.

They are routed to the DUT via the R&S®SMB100A used for RF modulation. The demodulated audio signals from the DUT are measured in the analyzer section of the R&S®UPP200/400/800. Since both test signal generation and analysis take place in the audio analyzer, the signals are optimally timed. As a result, measurement times are considerably shorter compared to separately operating instruments.

Parallel measurements for high throughput

The R&S®UPP200/400/800 offers two, four or eight parallel audio channels respectively, which enables simultaneous measurement of all relevant audio parameters and even FFT analysis with maximum resolution. Multichannel measurement considerably reduces the overall measurement time compared to instruments that can only process two channels at a time by using an audio switcher, for example.

High-end surround-sound applications, which use 16 or even more channels, can be measured with two or more R&S®UPP800 audio analyzers depending on the number of measurement channels required. The analyzers are cascaded so that all channels are measured in parallel. With the R&S®UPP-K800 control software, one R&S®UPP800 is selected as master and up to five other R&S®UPP200/400/800 analyzers can be added as slaves. The entire cascade acts as a single measuring instrument, controlled via the master unit. This simplifies remote control mode as applied in production systems, for example.

The ability to measure up to eight analog audio channels simultaneously and to synchronize generated and analyzed signals within the same instrument makes the R&S®UPP200/400/800 audio analyzers the fastest and most compact test instruments available on the market today.

See also:

www.rohde-schwarz.com/product/UPP

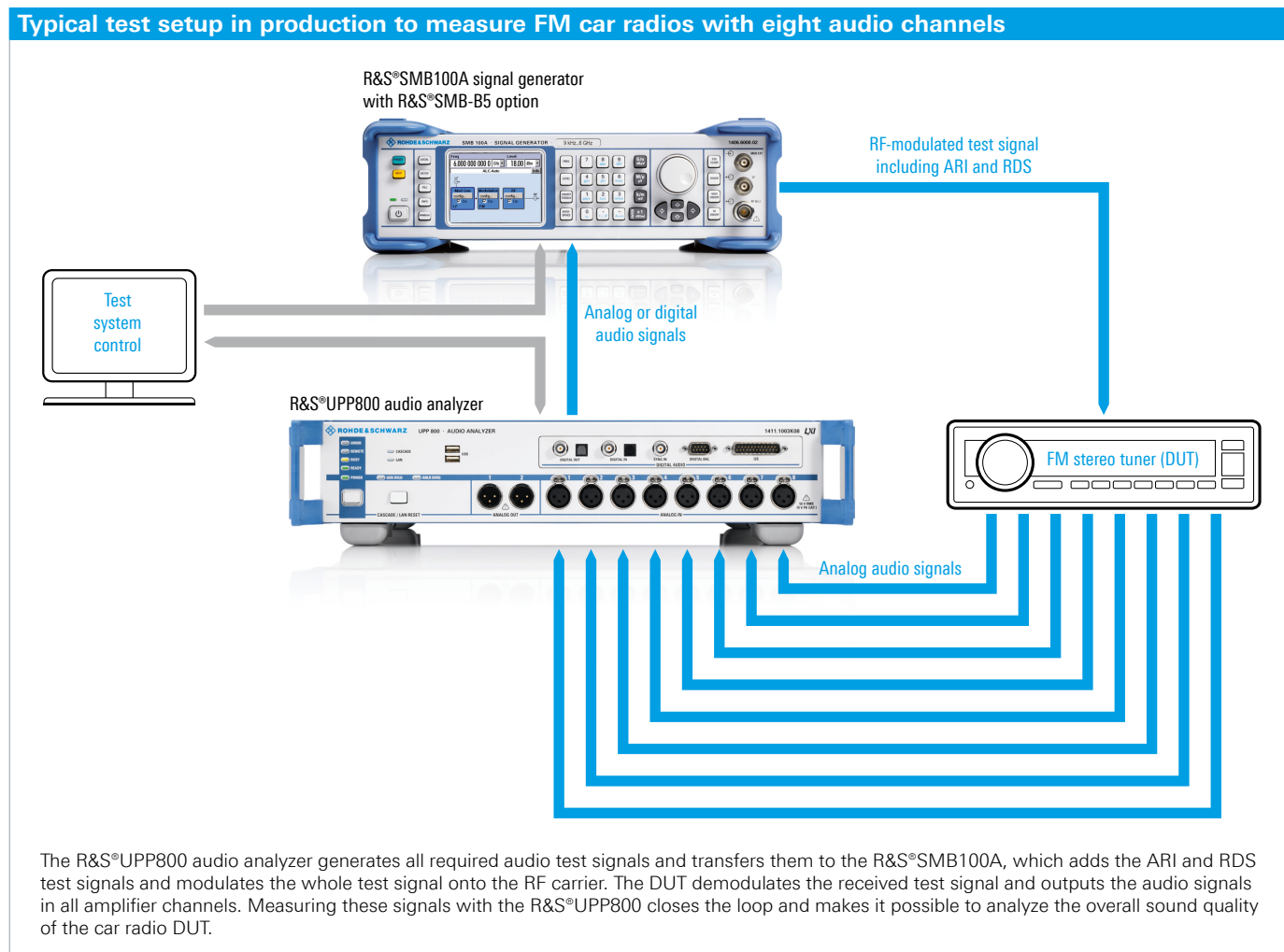

Rohde & Schwarz GmbH & Co. KG

Europe, Africa, Middle East +49 89 4129 137 74
 customersupport@rohde-schwarz.com
 North America 1 888 TEST RSA (1 888 837 8772)
 customer.support@rsa.rohde-schwarz.com
 Latin America +1 410 910 7988 | customersupport.la@rohde-schwarz.com
 Asia/Pacific +65 65 13 04 88 | customersupport.asia@rohde-schwarz.com
 www.rohde-schwarz.com

R&S® is a registered trademark of Rohde & Schwarz GmbH & Co. KG
 Trade names are trademarks of the owners | Printed in Germany (sv)
 Test your multichannel FM car radios | PD 5214.4407.92
 Version 01.00 | April 2010
 Data without tolerance limits is not binding | Subject to change
 © 2010 Rohde & Schwarz GmbH Co. KG | 81671 München, Germany